

268
HANDHELD CASES

292
UNIVERSAL
ENCLOSURES

318
HEAVY DUTY
AND ELECTRICAL
ENCLOSURES

342
DESKTOP AND
INSTRUMENT
CASES

348
DEVELOPMENT
BOARD
ENCLOSURES

367
ROOM SENSOR
ENCLOSURES

370
CUSTOM SIZED
ENCLOSURES

7550 series End panel enclosures

No design charges - No tooling

Simply provide your internal dimensions for a free quotation

Product overview

End panel enclosures manufactured in **custom** sizes to fit your PCB assembly and components.

Features

- Snap-together construction
- Four part end panel design
- Manufactured to your custom specifications
- Various material colour and specification options
- Manufactured to order on short lead-times

Options

- Manufactured in either HIPS UL94-HB, ABS acrylic capped or listed ABS UL94-V0
- CNC milling (holes, cut-outs, vents, pockets, pillars, windows)
- Screen printing/membranes/overlays

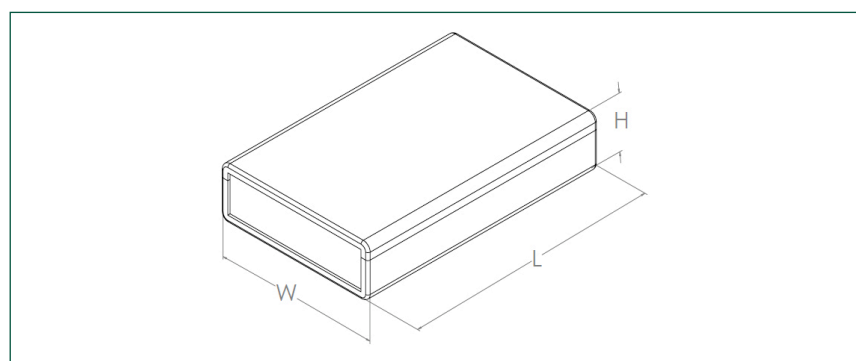

PART NO.	LENGTH (INT)	WIDTH (INT)	HEIGHT (INT)	LENGTH (EXT)	WIDTH (EXT)	HEIGHT (EXT)
7551	92mm	58mm	15mm	100mm	64mm	21mm
7552	112mm	64mm	25mm	120mm	70mm	31mm
7553	118mm	118mm	30mm	126mm	124mm	36mm
7554	144mm	70mm	32mm	152mm	76mm	38mm
7555	244mm	80mm	80mm	252mm	86mm	86mm
Custom size	Please advise dimensions					

Available in a range of colours:



KEY FEATURES

Snap together case | Four piece construction | End panels



PLASTIC ENCLOSURES

378

+44 (0)1638 716101 | sales@camdenboss.com | www.camdenboss.com

We operate a constant improvement policy, our products are subject to change without notice.

Vers 1



FM 28614